

## ATS-LCD6 Manual

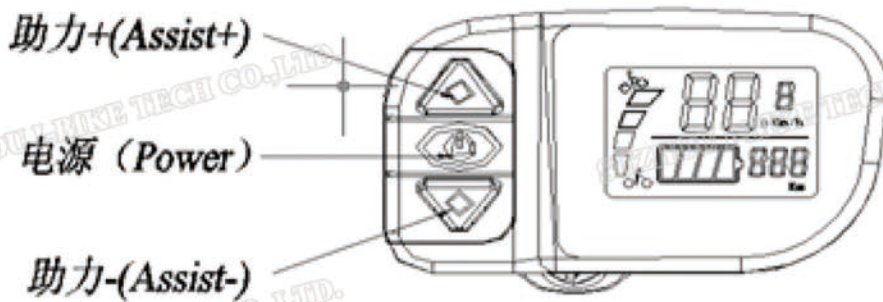

## Operation procedure

### 一、电源按钮功能 Power button function:

1、开机：按此按钮一秒钟，液晶开机

Power on: pressing the button for 1 seconds to power on;

2、关机：按此按钮五秒钟，液晶关机。

Power off: pressing the button for 5 seconds to power off.

3、模式切换：短按该按钮可以切换“ODO”“TRIP”两种模式。

Mode switch: Press this button to adjust the mode “ODO”“TRIP”

4、单次里程清零：在“TRIP”模式下，同时按下电源键与减档键3s，则单次里程清零。

Trip distance reset: Under the “TRIP” state, press the button of power source and shift down simultaneously for 3seconds, then the trip distance reset.

### 二、减档按钮功能： the function of “assist-”button

1、减档：短按此按钮进行减档操作。

Shift down: short press the button to shift down.



2、长按此按钮2秒钟可以开启或关闭液晶背光和大灯。

Press the button for 2s which is able to open or close LCD backlight and headlight.

### 三、加档按钮功能：the function of “assist+” button

1、加档：短按此按钮进行加档操作。

Shift up: short press the button to shift up.

2、6KM功能：长按此按钮2秒钟，可开启6KM功能；松开此按钮6KM功能立马撤销。

The function of 6KM: press the button for 2s to activate the function of 6KM; to loosen the button, the function will undo.

### 四、轮径设置：Wheel diameter setting

双按助力+/-按钮，进入轮径设置状态。出厂默认为L200（周长200cm）。通过短按Power（电源）按钮定位要调整的数字，通过单按+或-按钮调整数字。

Press the button “assist +” “assist -” simultaneously to enter the state of wheel diameter setting. The factory default is L200 (perimeter is 200cm), short press the power button locate the figure(diameter) that need to adjust, press the button + or - to adjust the figure.

### 五、最高限速 Speed limit

同时按下加档键与电源键10s，最高限速值在25Km/h与45Km/h切换一次，同时速度位置会相应闪烁显示最高限速值。

默认25Km/h限速。

Press the button of “assist +” and power for 10s simultaneously, the speed limit of 25Km/h and 45Km/h will change once, at the same time the speed part will blinking and show the highest speed limit figure.

The default speed limit is 25Km/h.

Program name: ATSLCD6-central-motor

Wheel diameter	perimeter
20	160
21	168
22	176
23	184
24	192
25	200
26	208
27	216
28	220
29	224

Suzhou I-Bike Tech Co., Ltd.

333, Xinguo Road, Gusu Dist, Jiangsu, 215007 China

E-mail & Skype ID: ebikemotor@126.com

All rights reserved by  i-BIKE